

Quiet Vandal-Pac

Dri-Prime® Pumps

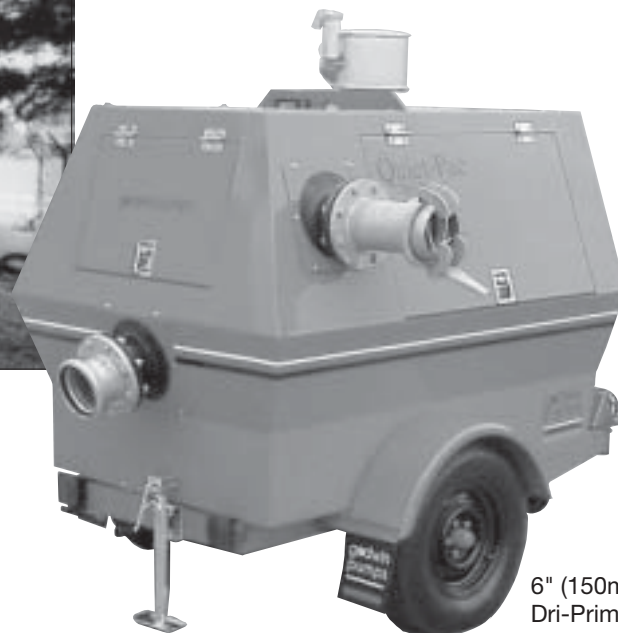

Municipal Pump Station Bypass



6" (150mm)
Dri-Prime Pump

If equipment security is a concern, the Quiet Vandal-Pac enclosure is the right choice. The Quiet Vandal-Pac houses the Godwin Dri-Prime pump in a specially designed enclosure that mounts directly to the trailer and allows pumping to continue while at the same time providing equipment protection and keeping engine and other noise to a minimum. The Quiet Vandal-Pac option is available for any Godwin pump model that can be mounted on a 30, 60 or 100 gallon (114, 227 or 379 liter) trailer. Sound levels are approximately 72 dBA at 30 feet (9M).

Features

- Self-contained unit provides cost-effective security.
- Lockable enclosure protects against vandalism and weather
- Three, hinged, lockable doors provide convenient access to operating controls and service locations while keeping out unauthorized personnel.
- Sound attenuation features include 14 gauge sheet metal construction lined with 1" (25mm) layer of polydamp acoustical sound deadening material, silenced muffler (cowl muffler) and silenced priming exhaust.
- Reduces operating noise to as low as 72 dBA at 30 feet (9M).
- Available for 4-, 6- or 8-inch Dri-Prime® pumps.

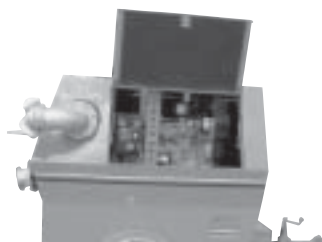

Hinged, lockable doors provide access to operating controls and service locations.

4-Inch Quiet Vandal-Pac Dimensions

Standard Unit: CD100M — John Deere 3016D, Highway Trailer

Weight: 2,034 lbs. (925 kg.)

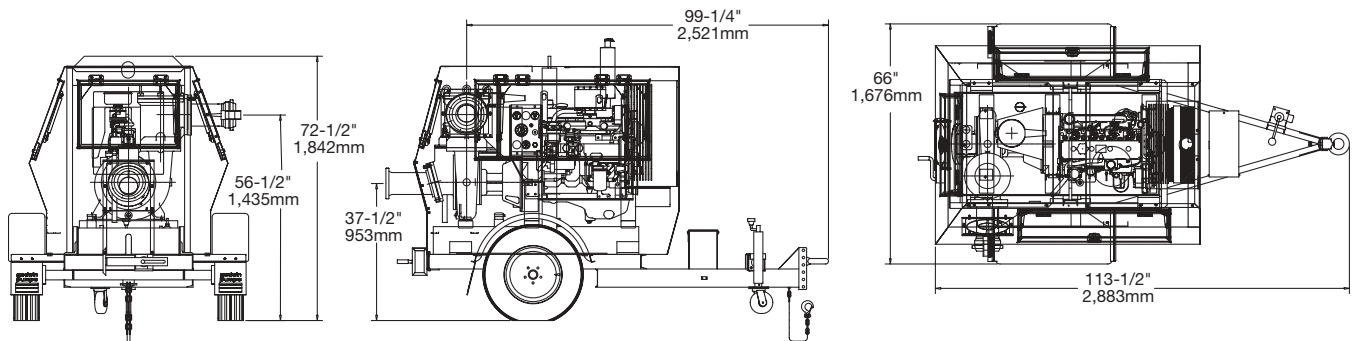

6-Inch Quiet Vandal-Pac Dimensions

Standard Unit: CD150M — John Deere 4045D, Highway Trailer

Weight: 3,650 lbs. (1,659 kg.)

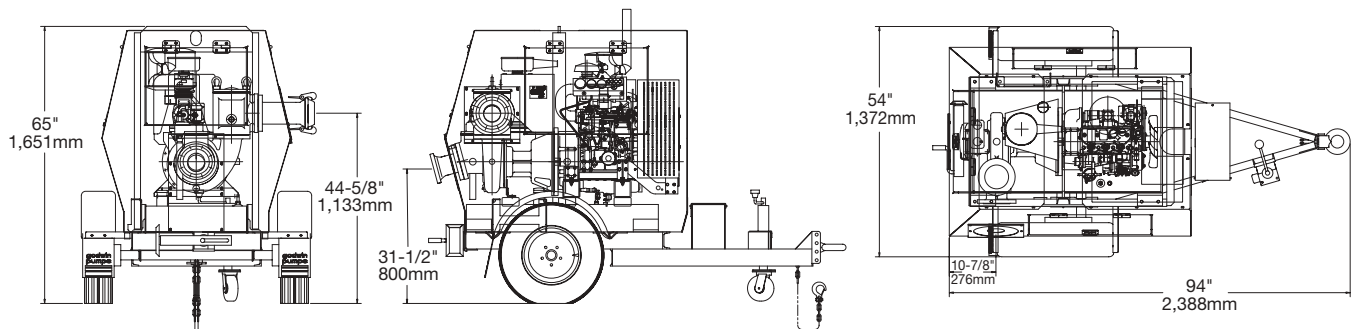

8-Inch Quiet Vandal-Pac

Standard Unit: CD200M — John Deere 4045D, Highway Trailer

Weight: 3,650 lbs. (1,659 kg.)

Please consult factory for dimensions.

NOTE: The Godwin CD225M 8" Dri-Prime pump is available in the Critically Silenced configuration. Refer to the Godwin Pumps Critically Silenced data sheet for additional details.

HOME OFFICES: One Floodgate Road, Bridgeport, NJ 08014, USA • (856) 467-3636 • Fax: (856) 467-4841
Quenington, Cirencester, Glos. GL7 5BX, UK • Tel: +44 (0)1285-750271 • Fax: +44 (0)1285-750352
E-mail: sales@godwinpumps.com • www.godwinpumps.com

LOCATIONS: Connecticut • Pennsylvania • New York • Ohio • Illinois • Maryland
Virginia • West Virginia • Georgia • South Carolina • North Carolina
Florida • Texas • Montana • California • Washington

godwin
pumps

